



Zagreb

PD-13500~PD-13521

Our Zagreb lights are elongated acrylic cones with square staves joining end to end and round rods penetrating the staves with rolled descending ring formations. Zagreb fixtures feature a very dramatic spun ring at top providing the basis for the upper framework and a much smaller ring at bottom for the final edge. These fixtures are actually a seamless blend of the classical with their traditional top ring, and of the modern with their semi-art deco straight and curved edges. Light throw is actually enhanced by the cone angle and we do offer a downlight option just in case side illumination is not enough to do the job.

~Zagreb Series~

Chandelier: CH-13501~CH-13515

Pendant: PD-13500~PD-13521

Ceiling Mt: CL-13500~CL-13508

Wall Mt: SC-13500~SC-13511

Bollard: BL-13500~BL-13511

Mounting: Lightsmith fixtures mount to standard 4" octagon electrical boxes unless otherwise specified. All hardware and canopies supplied.

Listing and Warranty: Lightsmith fixtures are Underwriters Laboratories listed and carry a standard three year warranty against defects in materials and labor beginning at date of shipment.



Fixture Specifications

PD-135
FIXTURE NUMBER
(Example: PD-13500)

~ **DIFFUSER**
(Example: BGA-ECH)

~ **METAL FINISH**
(Example: ABB)

~ **VOLTAGE**
 (120V)
 (277V)
 (347V)

~ **STEM=S+Lgth**
(Example: S-96")
CABLE=C+Lgth
(Example: C-96")
NR=Not required

~ **OPTIONS**
(Example: DIM, REM)

~ **MODIFICATIONS**
(Example: Custom Paint*)
Use "Notes" Box At Top To Explain Modifications

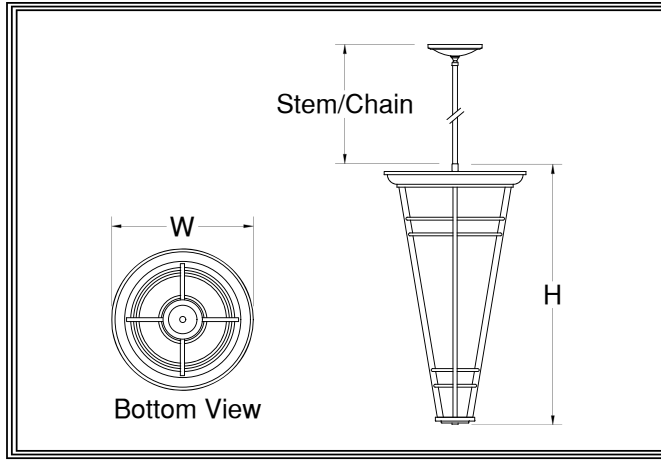

PD-135

Fixture Number Job Type

Job Name

Notes~Modifications

	Fixture Number	Dimensions	Lamping	Weight	Stem/Chain	Options
LED	<input type="checkbox"/> PD-13509	14w x 25h	2-13wL(2820 lm)	15 lbs	3' Std	IEM, REM, SPR**
	<input type="checkbox"/> PD-13510	18w x 32h	4-13wL(5640 lm)	23 lbs	6' Std	L213, L52
	<input type="checkbox"/> PD-13511	24w x 43h	6-13wL(8460 lm)	27lbs	9' Std	L213, L52
	<input type="checkbox"/> PD-13512	30w x 54h	12-13wL(16920 lm)	29 lbs	9' Std	L223, L83
	<input type="checkbox"/> PD-13513	36w x 65h	16-13wL(22560 lm)	35 lbs	12' Std	L223, L83
INCANDESCENT	<input type="checkbox"/> PD-13520	14w x 25h	4-75wA(4800 lm)	13 lbs	3' Std	L38
	<input type="checkbox"/> PD-13500	18w x 32h	8-75wA(9600 lm)	19 lbs	6' Std	L52
	<input type="checkbox"/> PD-13521	24w x 43h	12-75wA(14400 lm)	21 lbs	9' Std	L52
	<input type="checkbox"/> PD-13501	30w x 54h	16-75wA(19200 lm)	27 lbs	9' Std	L83
	<input type="checkbox"/> PD-13502	36w x 65h	20-75wA(24000 lm)	32 lbs	12' Std	L83
FLUORESCENT	<input type="checkbox"/>					

~Single Circuit Standard Wiring~

**All LED Fixtures

DIFFUSER	<input type="checkbox"/> BGA: Beige Alabaster Acrylic	<input type="checkbox"/> GRA: Green Edge Acrylic	<input type="checkbox"/> ECH: Etched*
	<input type="checkbox"/> NHA: Natural Horn Acrylic	<input type="checkbox"/> EGA: Earth Green Acrylic	*Etched option creates a matte, non-glossy finish on one side of the diffuser. (Example: WOA-ECH)
	<input type="checkbox"/> WHA: White Alabaster Acrylic	<input type="checkbox"/> DGA: Deep Gold Acrylic	
	<input type="checkbox"/> HNA: Honey Alabaster Acrylic	<input type="checkbox"/> SBA: Sea Blue Acrylic	
	<input type="checkbox"/> WOA: White Opal Acrylic	<input type="checkbox"/> PHA: Purple Haze Acrylic	

	SOLID BRASS FINISHES	PAINTED METAL FINISHES	ALUMINUM FINISHES	STAINLESS STEEL FINISHES
METAL FINISH	<input type="checkbox"/> ABB: Antique Brass	<input type="checkbox"/> DGP: Dark Green	<input type="checkbox"/> SAA: Satin Aluminum	<input type="checkbox"/> NA
	<input type="checkbox"/> SBB: Satin Brass	<input type="checkbox"/> VGP: Verde Green	<input type="checkbox"/> SNA: Satin Nickel	<input type="checkbox"/>
	<input type="checkbox"/> PBB: Polished Brass	<input type="checkbox"/> CGP: Charcoal Gray	<input type="checkbox"/> PAA: Polished Aluminum	<input type="checkbox"/>
	<input type="checkbox"/> ANB: Antique Nickel	<input type="checkbox"/> MBP: Medium Bronze	<input type="checkbox"/> BBA: Burnished Bronze	<input type="checkbox"/>
	<input type="checkbox"/> SNB: Satin Nickel	<input type="checkbox"/> SBP: Satin Black	<input type="checkbox"/> RNA: Red Naval Bronze	<input type="checkbox"/>
	<input type="checkbox"/> PNB: Polished Nickel	<input type="checkbox"/> DBP: Dark Bronze	<input type="checkbox"/> SGA: Satin Gold	<input type="checkbox"/>
	<input type="checkbox"/> AZB: Antique Bronze	<input type="checkbox"/> LBP: Light Bronze	<input type="checkbox"/> SBA: Satin Bronze	<input type="checkbox"/>
	<input type="checkbox"/> SZB: Satin Bronze	<input type="checkbox"/> MGP: Medium Gold	<input type="checkbox"/> ORA: Oil Rubbed Bronze	<input type="checkbox"/>
	<input type="checkbox"/> PZB: Polished Bronze	<input type="checkbox"/> SCP: Sponged Copper	<input type="checkbox"/> SCA: Satin Copper	<input type="checkbox"/>
	<input type="checkbox"/> CSB: Custom Brass*	<input type="checkbox"/> CSP: Custom Paint*	<input type="checkbox"/> CSA: Custom Aluminum*	<input type="checkbox"/>

OPTIONS	<input type="checkbox"/> L38: 38wLED R40 Downlight	<input type="checkbox"/> L213: 2-13wCLEU Uplight	<input type="checkbox"/> SPR: Surge protector
	<input type="checkbox"/> L52: 52wLED R40 Downlight	<input type="checkbox"/> L223: 2-23wCLEU Uplight	<input type="checkbox"/> IEM: Integral Emer.Ballast
	<input type="checkbox"/> L83: 83wLED R40 Downlight	<input type="checkbox"/>	<input type="checkbox"/>
	<input type="checkbox"/> DIM: Dimming Driver (std)	<input type="checkbox"/>	<input type="checkbox"/>
	<input type="checkbox"/> REM: Remote Emer.Driver	<input type="checkbox"/>	<input type="checkbox"/>