



Killarney

SC-5500~SC-5511

Our Killarney lights are quietly elegant blends of heavy bar stock staves and rings with virgin acrylics. The result of this union is a classic design totally free of mechanical fasteners and any other visible means of joining things together. All metal parts to the frame are brazed or tig welded and then ground to right angle corners. The effect is very old school 1920's and even before that when European craftsmen were fresh off the boat with something to prove. We offer Killarney fixtures in brass, aluminum, and stainless steel. The Killarney sconce can be exterior mounted.

~Killarney Series~

- Chandelier: CH-5500~CH-5511
- Pendant: PD-5500~PD-5531
- Ceiling Mount: CL-5500~CL-5508
- Wall Mount: SC-5500~SC-5511
- Bollard: BL-5500~BL-5511

Mounting: Lightsmith fixtures mount to standard 4" octagon electrical boxes unless otherwise specified. All hardware and canopies supplied.

Listing and Warranty: Lightsmith fixtures are Underwriters Laboratories listed and carry a standard three year warranty against defects in materials and labor beginning at date of shipment.



Fixture Specifications

SC-55	~	DIFFUSER (Example: BGA-ECH)	~	METAL FINISH (Example: ABB)	~	VOLTAGE <input type="checkbox"/> (120V) <input type="checkbox"/> (277V) <input type="checkbox"/> (347V)	~	NR STEM=S+Lgth (Example: S-96") CHAIN=C+Lgth (Example: C-96") NR=Not required	~	OPTIONS (Example: DIM,IEM)	~	MODIFICATIONS (Example: Custom Paint) Use "Notes" Box At Top To Explain Modifications
-------	---	--------------------------------	---	--------------------------------	---	--	---	--	---	-------------------------------	---	---

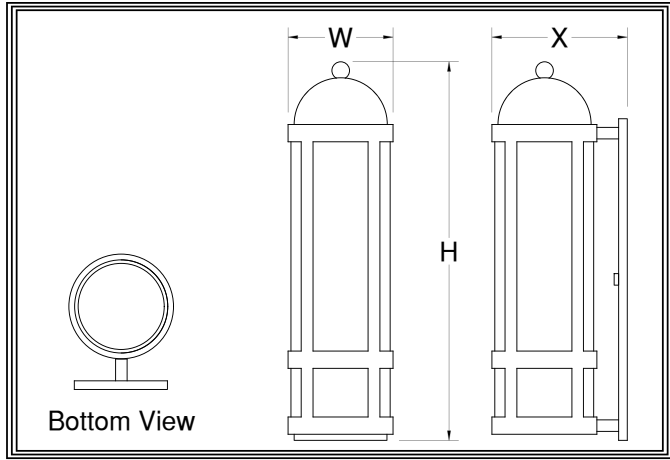

SC-55

Fixture Number Job Type

Job Name

Notes~Modifications

	Fixture Number	Dimensions	Lamping	Weight	Options
LED	<input type="checkbox"/> SC-5509	4w x 15h x 5x	2-13wLLED (2820 lumens)	10 lbs	WLM
	<input type="checkbox"/> SC-5510	6w x 22h x 8x	3-13wLLED (4230 lumens)	12 lbs	WLM
	<input type="checkbox"/> SC-5511	8w x 29h x 10x	4-13wLLED (5640 lumens)	16 lbs	WLM REM,SPR**
INCANDESCENT	<input type="checkbox"/> SC-5500	4w x 15h x 5x	2-60wT10 (1600 lumens)	8 lbs	WLM
	<input type="checkbox"/> SC-5501	6w x 22h x 8x	3-60wA (2400 lumens)	10 lbs	WLM
	<input type="checkbox"/> SC-5502	8w x 29h x 10x	4-60wA (3200 lumens)	14 lbs	WLM

~Single Circuit Standard Wiring~

**All LED Fixtures

DIFFUSER	<input type="checkbox"/> BGA: Beige Alabaster Acrylic	<input type="checkbox"/> GRA: Green Edge Acrylic	<input type="checkbox"/> ECH: Etched*
	<input type="checkbox"/> NHA: Natural Horn Acrylic	<input type="checkbox"/> EGA: Earth Green Acrylic	*Etched option creates a matte, non-glossy finish on one side of the diffuser. (Example: WOA-ECH)
	<input type="checkbox"/> WHA: White Alabaster Acrylic	<input type="checkbox"/> DGA: Deep Gold Acrylic	
	<input type="checkbox"/> HNA: Honey Alabaster Acrylic	<input type="checkbox"/> SBA: Sea Blue Acrylic	
	<input type="checkbox"/> WOA: White Opal Acrylic	<input type="checkbox"/> PHA: Purple Haze Acrylic	

	SOLID BRASS FINISHES	PAINTED METAL FINISHES	ALUMINUM FINISHES	STAINLESS STEEL FINISHES
METAL FINISH	<input type="checkbox"/> ABB: Antique Brass	<input type="checkbox"/> DGP: Dark Green	<input type="checkbox"/> SAA: Satin Aluminum	<input type="checkbox"/> SSS: Satin
	<input type="checkbox"/> SBB: Satin Brass	<input type="checkbox"/> VGP: Verde Green	<input type="checkbox"/> SNA: Satin Nickel	<input type="checkbox"/> DSS: Distressed
	<input type="checkbox"/> PBB: Polished Brass	<input type="checkbox"/> CGP: Charcoal Gray	<input type="checkbox"/> PAA: Polished Aluminum	<input type="checkbox"/> PSS: Polished
	<input type="checkbox"/> ANB: Antique Nickel	<input type="checkbox"/> MBP: Medium Bronze	<input type="checkbox"/> BBA: Burnished Bronze	<input type="checkbox"/> HSS: Hammered
	<input type="checkbox"/> SNB: Satin Nickel	<input type="checkbox"/> SBP: Satin Black	<input type="checkbox"/> RNA: Red Naval Bronze	<input type="checkbox"/>
	<input type="checkbox"/> PNB: Polished Nickel	<input type="checkbox"/> DBP: Dark Bronze	<input type="checkbox"/> SGA: Satin Gold	<input type="checkbox"/>
	<input type="checkbox"/> AZB: Antique Bronze	<input type="checkbox"/> LBP: Light Bronze	<input type="checkbox"/> SBA: Satin Bronze	<input type="checkbox"/>
	<input type="checkbox"/> SZB: Satin Bronze	<input type="checkbox"/> MGP: Medium Gold	<input type="checkbox"/> ORA: Oil Rubbed Bronze	<input type="checkbox"/>
	<input type="checkbox"/> PZB: Polished Bronze	<input type="checkbox"/> SCP: Sponged Copper	<input type="checkbox"/> SCA: Satin Copper	<input type="checkbox"/>
	<input type="checkbox"/> CSB: Custom Brass*	<input type="checkbox"/> CSP: Custom Paint*	<input type="checkbox"/> CSA: Custom Aluminum*	<input type="checkbox"/>
	<input type="checkbox"/>			<input type="checkbox"/> CSS: Custom SS*

OPTIONS	<input type="checkbox"/> REM: Remote Emer. Ballast	<input type="checkbox"/> DIM: Dimming Driver (std)	<input type="checkbox"/> SPR: Surge Protector
	<input type="checkbox"/>	<input type="checkbox"/> WLM: Wet Location Mounting	<input type="checkbox"/>
	<input type="checkbox"/>		<input type="checkbox"/>
	<input type="checkbox"/>		<input type="checkbox"/>
	<input type="checkbox"/>		<input type="checkbox"/>