



Hedgeman

3004-CC~3018-CC

Our Hedgeman fixtures are stylish pendants, sconces, and ceiling lights. Their traditional-modern appearance comes from using a modified Greek Key design with a square inside a square motif. Hedgeman fixtures are bright, and especially powerful when using our modular LED options. The uni-directional nature of the linear LEDs we put into them really propels light output through the diffuser panes and down to the floor. And stylish side panels complete the look. These are the fixtures you would find in historic buildings as well as new office spaces. Very adaptable.

~Hedgeman Series~

Chandelier:3041-CHC~3073-CHC

Pendant:3001-PC~3017-PC

Ceiling Mt.:3004-CC~3016-CC

Wall Mt.:3001-WC~3013-WC

S-Pendant:3003-SC~3015-SC

Mounting: Lightsmith fixtures mount to standard 4" octagon electrical boxes unless otherwise specified. All hardware and canopies supplied.

Listing and Warranty: Lightsmith fixtures are Underwriters Laboratories listed and carry a standard three year warranty against defects in materials and labor beginning at date of shipment.

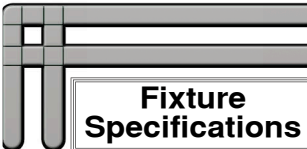

Fixture Specifications



Manufacturers of Fine Custom Lighting ~ Ph:434-528-5809 ~ Fx:434-845-7907 ~ Web:Info@Ltsmith.com

©2020 Lightsmith

CC-30S

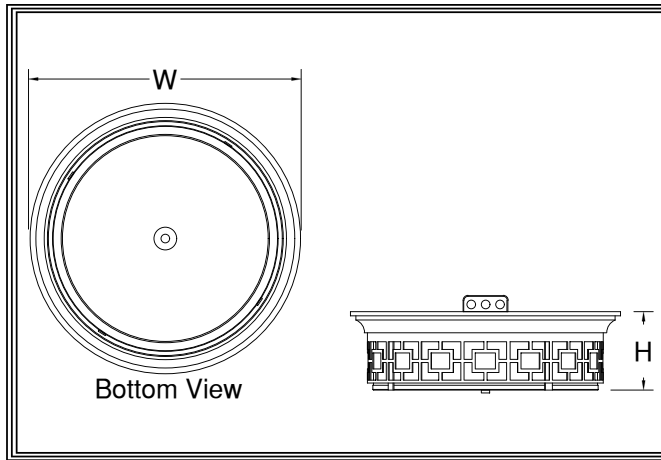

30__-CC

Fixture Number Job Type

Job Name

Notes~Modifications

	Fixture Number	Dimensions	Lamping	Weight	Options
LED	<input type="checkbox"/> 3004-CC	20w x 6h	4-13wCLED (5640 lm)	15 lbs	REM,SPR ** L123
	<input type="checkbox"/> 3005-CC	24w x 7h	6-13wCLED (8460 lm)	21 lbs	
INCANDESCENT	<input type="checkbox"/> 3016-CC	20w x 6h	6-60wA (4800 lm)	13 lbs	N75 N100
	<input type="checkbox"/> 3018-CC	24w x 7h	8-60wA (6400 lm)	19 lbs	
FLUORESCENT	<input type="checkbox"/>				

~Single Circuit Standard Wiring~

**All LED Fixtures

DIFFUSER	Options	Options	Options
<input type="checkbox"/> BGA: Beige Alabaster Acrylic	<input type="checkbox"/> GRA: Green Edge Acrylic	<input type="checkbox"/> ECH: Etched*	*Etched option creates a matte, non-glossy finish on one side of the diffuser. (Example:WOA-ECH)
<input type="checkbox"/> NHA: Natural Horn Acrylic	<input type="checkbox"/> EGA: Earth Green Acrylic		
<input type="checkbox"/> WHA: White Alabaster Acrylic	<input type="checkbox"/> DGA: Deep Gold Acrylic		
<input type="checkbox"/> HNA: Honey Alabaster Acrylic	<input type="checkbox"/> SOG: Streaked Opal Glass		
<input type="checkbox"/> WOA: White Opal Acrylic	<input type="checkbox"/> WOG: White Opal Glass		

METAL FINISH	SOLID BRASS FINISHES	PAINTED METAL FINISHES	ALUMINUM FINISHES	STAINLESS STEEL FINISHES
<input type="checkbox"/> ABB: Antique Brass	<input type="checkbox"/> DGP: Dark Green	<input type="checkbox"/> SAA: Satin Aluminum	<input type="checkbox"/> NA	
<input type="checkbox"/> SBB: Satin Brass	<input type="checkbox"/> VGP: Verde Green	<input type="checkbox"/> SNA: Satin Nickel	<input type="checkbox"/>	
<input type="checkbox"/> PBB: Polished Brass	<input type="checkbox"/> CGP: Charcoal Gray	<input type="checkbox"/> PAA: Polished Aluminum	<input type="checkbox"/>	
<input type="checkbox"/> ANB: Antique Nickel	<input type="checkbox"/> MBP: Medium Bronze	<input type="checkbox"/> BBA: Burnished Bronze	<input type="checkbox"/>	
<input type="checkbox"/> SNB: Satin Nickel	<input type="checkbox"/> SBP: Satin Black	<input type="checkbox"/> RNA: Red Naval Bronze	<input type="checkbox"/>	
<input type="checkbox"/> PNB: Polished Nickel	<input type="checkbox"/> DBP: Dark Bronze	<input type="checkbox"/> SGA: Satin Gold	<input type="checkbox"/>	
<input type="checkbox"/> AZB: Antique Bronze	<input type="checkbox"/> LBP: Light Bronze	<input type="checkbox"/> SBA: Satin Bronze	<input type="checkbox"/>	
<input type="checkbox"/> SZB: Satin Bronze	<input type="checkbox"/> MGP: Medium Gold	<input type="checkbox"/> ORA: Oil Rubbed Bronze	<input type="checkbox"/>	
<input type="checkbox"/> PZB: Polished Bronze	<input type="checkbox"/> SCP: Sponged Copper	<input type="checkbox"/> SCA: Satin Copper	<input type="checkbox"/>	
<input type="checkbox"/> CSB: Custom Brass*	<input type="checkbox"/> CSP: Custom Paint*	<input type="checkbox"/> CSA: Custom Aluminum*	<input type="checkbox"/>	

OPTIONS	Options	Options
<input type="checkbox"/> N75: 75wPar30 Downlight	<input type="checkbox"/> L123: 1-23wCLED Downlight	<input type="checkbox"/> SPR: Surge protector
<input type="checkbox"/> N100: 100wPar30 Downlight	<input type="checkbox"/>	<input type="checkbox"/>
<input type="checkbox"/> DIM: Dimming Driver (Std)	<input type="checkbox"/>	<input type="checkbox"/>
<input type="checkbox"/> REM: Remote Emer.Ballast	<input type="checkbox"/>	<input type="checkbox"/>
<input type="checkbox"/>	<input type="checkbox"/>	<input type="checkbox"/>

30__-CC ~ ~ ~ ~ NR ~ ~

FIXTURE NUMBER (Example: 3004-CC) DIFFUSER (Example: BGA-ECH) METAL FINISH (Example: ABB) VOLTAGE (120V, 277V, 347V) STEM=S+Lgth (Example:S-96") CHAIN=C+Lgth (Example:C-96") NR=Not required OPTIONS (Example:DIM,REM) MODIFICATIONS (Example:Custom Paint) Use "Notes" Box At Top To Explain Modifications